

A woman with short brown hair, wearing a red ribbed sweater, is looking down at a printed brochure. A man in a blue shirt and striped tie is looking at the same brochure. They are in a print shop, with a rack of brochures and a printer visible in the background. The scene is brightly lit, and the overall atmosphere is professional and focused on quality printing.

Kodak

NexPress SE

Digital Production

Color Platform

with Print Genius

New
applications
markets
revenue

Profit from the changes occurring in your business

The market is changing...

The print market is experiencing rapid change. Your clients realize they can improve their communications through shorter runs of customized, high impact color documents. At the same time, they are demanding superior image quality on a wide range of substrates, all delivered in record times with lower print spends.

Position yourself to profit from those changes

With **Kodak NexPress** SE Digital Production Color Presses, you can be ready to deliver exactly what your clients are demanding. Market-edge image quality, lightning-fast processing power and industry-leading uptime and availability are just a few of the outstanding features that can help position you to:

- ▶ Reduce labor costs
- ▶ Increase print volume
- ▶ Drive higher margins

Kodak's dynamic digital press family can help you run more jobs per shift, drive more profit per page and reap the benefits of new, higher-value capabilities.



Your clients' demands are changing. Digital solutions help meet these demands while complementing traditional services in an array of markets:

"How can I handle shrinking offset print runs and capitalize on our current workflow?"

"I see expanding interest in photo books and other personalized photo products—how can I expand my offerings to take advantage of this opportunity?"

"My client is looking to get more promotional opportunities out of the statements they send customers—how can I help them?"

Answer these demands and more with the **Kodak Digital Presses** that can deliver higher margin results—dependably, consistently and reliably.

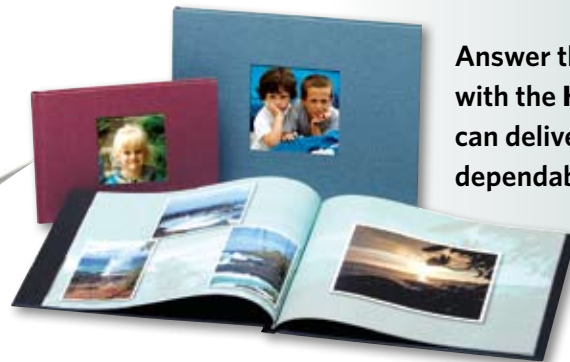

Energize your business today...

...easily expand tomorrow

The family of **Kodak NexPress SE** Digital Production Color Presses offer choices that can help you profit from the changes occurring in your business.

Each press offers a similar range of rich and robust features so you can make choices, not trade-offs. Choose the press that best meets your needs, then add the components you need to fit your business and workflow.

When the time is right, our flexible design is ready to expand as your business needs change and grow.

The **NexPress SE Platform** now features *Print Genius*, a suite of quality control tools and options that help you manage and maintain peak quality throughout your production run. The *Print Genius* quality suite encompasses hardware, software and materials science innovations to optimize quality and consistency from the first sheet to the last, day after day.



The **Kodak NexPress SE2500** Digital Production Color Press can help expand your application range and drive higher margins.



The **Kodak NexPress SE3000** Digital Production Color Press can help drive more jobs per shift and more profit per page, energizing your business today and into the future. The **NexPress SE3000** Press is the most flexible press in the SE family, offering the widest array of Fifth Imaging Unit Solutions to meet your expanding application needs.



The **Kodak NexPress SE3600** Digital Production Color Press offers game-changing power and exceptional reliability to help you dominate your market and maximize your bottom line. The **NexPress SE3600** Press is Kodak's most productive press at 120 ppm.

Kodak NexPress SE Digital Production Color Platform with Print Genius helps drive increased opportunity, expanded growth and market-dominating power.

With Print Genius, the advantages are

Kodak NexPress SE Digital Production Color Presses with Print Genius feature imaging technologies designed to produce market leading image quality—job to job and day to day. Every aspect of Print Genius optimizes image quality, productivity and cost control.

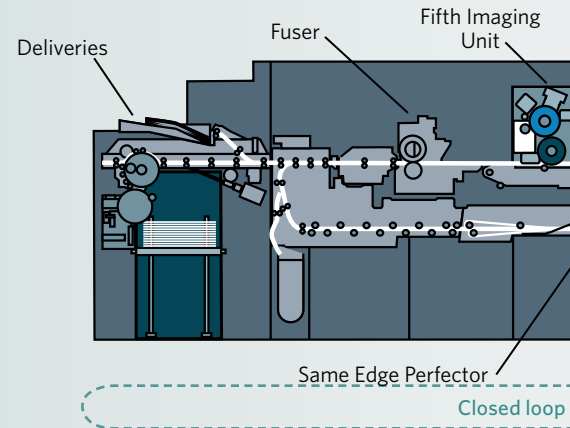

Print Genius



Image science

- ▶ Accuracy and speed to color
- ▶ Match critical **Pantone® PMS** and **Goe** colors
- ▶ Higher image quality and image consistency than previous
- ▶ Smooth flat fields and gradients

Closed-loop calibration

Five minutes is all it takes to analyze output and feed critical data back to the system for closed-loop color calibration, helping you optimize quality with minimal downtime. The unique **Kodak NexPress** Intelligent Calibration System (ICS) automates the process of checking and maintaining print uniformity.

Enhanced dry inks and developers

Newly reformulated **Kodak NexPress** Enhanced Dry Ink and Developers provide vibrant colors and consistent spot color matching, smooth flat fields and gradients, and the unique ability to match the ink laydown gloss level to the substrate being printed. You can realize consistent, high image quality with reduced print waste, optimizing running costs.

Scaleability and flexibility

Kodak gives you the options to craft a solution that's perfect for you—today and into the future.

- ▶ Business-building **Kodak NexPress** Fifth Imaging Unit Solutions provide dimensional print, inline coating, gamut expansion, spot colors, off-line glossing and secure MICR printing.
- ▶ Your press can grow and change with new features and accessories when application needs change.
- ▶ An array of inline and near-line feeding and finishing options improves your operation's productivity and subsequent turnaround time.
- ▶ Powerful, scalable front end configuration choices support complex variable data or image-intensive jobs.



e built right in

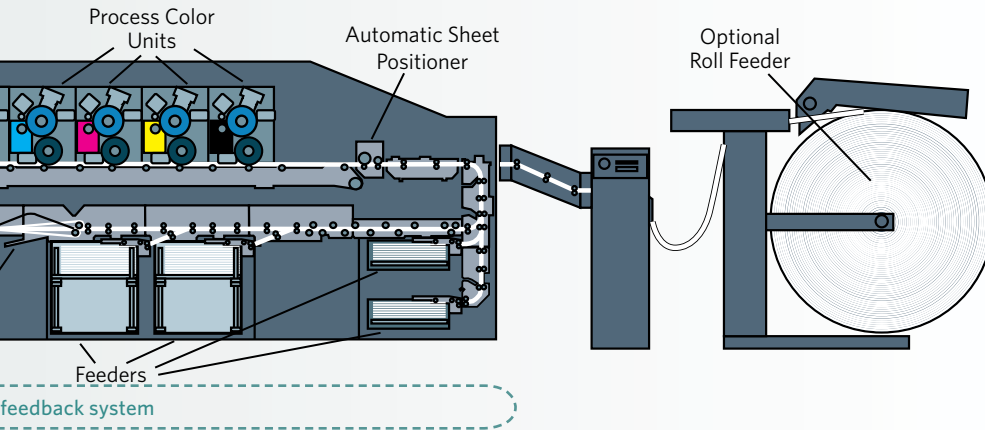

Quality assurance

- ▶ Increases uptime with closed loop feedback system
- ▶ Maximizes operator efficiency
- ▶ Increases output at peak quality with **Kodak NexPress** Intelligent Calibration System

Benchmark productivity

Drive more jobs per shift and more profits per page with presses that deliver highly productive operational performance.

- ▶ A choice of 2500, 3000, or 3600 A3+ 5/0 sheets per hour capability (83, 100, or 120 ppm).
- ▶ A press-like design maximizes throughput and productivity, so there is no slowdown for substrate types, weights, sizes or 5-color printing.
- ▶ The powerful **Kodak NexPress** Front End combines proprietary hardware, a high end computer with RAID storage, and leading edge software to handle even the most complex variable data jobs with ease. The **NexPress** System was the first digital cut sheet press solution to feature the **Adobe** PDF Print Engine, which eliminated timely and error-prone **Postscript** translations.

Workflow productivity

- ▶ Processes files 30-70% faster
- ▶ Boosts VDP performance with enhanced object caching
- ▶ Minimizes downtime between jobs

The current **NexPress** Front End raises the bar by eliminating transparency issues and employing new caching algorithms to increase VDP processing performance, saving significant processing time for complex jobs such as photo services and high-end direct mail.

- ▶ An open architecture integrates seamlessly into **Kodak Prinergy** Workflow Systems and is compatible with existing workflows.



The bottom line

Kodak offers choices to help ensure Total Cost of Ownership is managed while improving your ability to make a profit.

- ▶ The overall productivity of a **NexPress** Press lets you print more jobs, fast.
- ▶ Choice of **Kodak NexPress** Front Ends that incorporate rich features, reducing costly errors and rework.
- ▶ Fifth Imaging Unit Solutions and optional **Kodak NexPress** Glossing Unit enable you to productively achieve higher margins on the most demanding jobs.
- ▶ ORCs (Operator Replaceable Components) allow operators to replace critical press parts for maximum system performance. Excellent image quality is consistently maintained, cost is controlled, and uptime is increased.



Choices that help take you beyond your current capabilities

Magnify the attributes of any **NexPress** Press by choosing from complementary workflow, front end, feeding, finishing and business development options—choices that can help you design a solution to drive higher profits.



NexPress Front Ends

A choice of radically open, highly productive **Kodak NexPress** Front Ends deliver industry-leading PDF Print Engine processing with exceptional quality.

Each front end can be configured for a variety of customer environments, from a self-contained prepress and print on demand solution to a highly automated component tied to a **Kodak Prinergy** Workflow System or integrated with other third-party workflows.

Kodak NexPress V Front End

The V Front End delivers a rich set of prepress tools in a unified, simple to use platform that is scalable to meet future needs.

Kodak NexPress Vp Front End

The Vp Front End provides more power and unique photographic ICC profiles ideal for high volume, photo-intensive applications.

Integrated solutions that can adapt and expand to meet your requirements

Kodak Unified Workflow Solutions help simplify and automate your entire workflow. Robust options are available to support complex workflows such as variable data printing, transaction printing, web-to-print and photo services.

Kodak SmartBoard Document Mastering Software

PDF-based workflow allows you to manage both black and white and color jobs on **Kodak** Digital Presses, maximizing operational efficiency.

Kodak Prinergy Workflow System

Streamline production from original file to final printed job with modular, open, scalable software that can improve productivity, resource allocation, and ultimately, your bottom line.

Third party integration

Kodak NexPress Presses and their related components are designed to be radically open—easing integration into many established third-party workflow environments.





Application flexibility

Substrate weight and size don't have to be limitations of digital printing. Proven compatibility with more than 600 substrates means you can produce a full range of applications to meet diverse market needs.

- ▶ Coated, uncoated, and synthetics, including standard offset paper, selected packaging board and textured paper, specialty substrates, magnetic and photo papers.
- ▶ The ability to independently extend the paper catalog and adjust the press to other substrates' unique characteristics enables you to more readily accept client-specific stocks.

Build your business with unique Kodak NexPress Fifth Imaging Unit Solutions

Expand your business and deliver higher-impact communications to your customers with Kodak NexPress Intelligent Dimensional Coating, Intelligent Color, Coating, MICR and Glossing Solutions, five unique capabilities enabled by Fifth Imaging Unit Solutions.

Business development services that help maximize your potential

Kodak MarketMover Business Development Services combine experienced consultants with comprehensive sales and marketing resources and a vast suite of services that include on-site training and educational seminars. To learn more about Kodak MarketMover Services, visit marketmover.kodak.com.

Feeding and finishing components boost throughput consistently and reliably

Expand your capabilities and drive higher margin jobs with integrated feeding and finishing options that increase productivity as they expand your application range.

- ▶ High-capacity paper feeders offer uninterrupted printing. A roll feeding system increases productivity of the press while helping to lower paper and labor costs.
- ▶ Compatibility with inline and near-line finishing devices delivers professional-looking jobs produced at press-rated speeds.



Kodak NexPress Glossing Unit

When combined with the Fifth Imaging Unit, the optional Glossing Unit produces easily recyclable prints with an outstanding laminate-like gloss, for higher marketing impact and surface protection. The result is wow-factor impact, happy clients and the potential for higher margins that can be achieved from higher price points.



Trust in Kodak

Kodak NexPress Digital Production Color Presses are just the beginning of what Kodak has to offer to help support your business growth. Our environmental responsibility, expert service organizations, and proven commitment to the graphic arts industry are all part of our comprehensive approach to earning your confidence.

Good for your business, better for the planet



Environmental responsibility is a key priority at Kodak. Kodak is committed to sustainability worldwide. We recognize that we have a role to play in helping society prosper by driving business growth in a responsible manner that creates value for all stakeholders. **Kodak NexPress** SE Digital Production Color Platform helps protect our environment while consistently producing outstanding printed materials:

Better recycling

- ▶ Recycled materials are used in manufacturing wherever feasible.
- ▶ ORCs are recyclable and can be rotated for extended life.
- ▶ Printed sheets are easily de-inked, improving paper recycling efforts.

Reduced natural resource consumption

- ▶ Substrate flexibility to run many recycled and Forest Stewardship Council (FSC) approved papers.

Reduced waste

- ▶ Intelligent system monitors and adjusts color accuracy and registration, producing more sellable prints and reducing waste.

Cleaner operation

- ▶ Dry Inks contain no VOC's (Volatile Organic Compounds).
- ▶ High-gloss finished sheets utilizing dry inks are easily recycled.
- ▶ Dry Inks do not contain hazardous materials and do not require a hazardous waste removal process.

CPSIA General Conformity

- ▶ In accordance with section 102 of the Consumer Product Safety Improvement Act (CPSIA) of 2008, Lead and its compounds are not used in the manufacture of **Kodak NexPress** Dry Inks or **Kodak NexPress** Fuser Fluids.
- ▶ In addition, these products are not manufactured with the following phthalate materials: DEHP, DBP, BBP, DINP, DIDP, or DnOP.

Kodak and you—transforming the industry together

As an innovator in imaging, color, and printing technology, Kodak offers you one of the broadest arrays of integrated graphic communications solutions in the industry. With premier printing solutions and the expert resources of **Kodak** Service & Support, Kodak helps you deliver relevant, unique solutions for your clients through market-leading technologies, products and services. The combination of our deep portfolio and wide experience enables you to be faster, more efficient, more productive and better able to expand your business.



2005
Kodak NexPress
Fifth Imaging Unit Solution

2009
Kodak NexPress
Dimensional Printing System

To learn more about solutions from Kodak:

Visit graphics.kodak.com
Or in North America, call +1-866-563-2533.

Produced using **Kodak** Technologies.

Eastman Kodak Company
343 State Street
Rochester, NY 14650 USA

© Kodak, 2009. Kodak, MarketMover, NexPress, Prinergy and Smartboard are trademarks of Kodak. Pantone, PMS and Goe are trademarks of Pantone, Inc.

Manufacturing of **Kodak NexPress** Presses is ISO 9001:2000 and ISO 14001:2004 certified. **Kodak NexPress** Digital Production Color Presses are **Pantone PMS** and **Pantone Goe** licensed.

Subject to technical change without notice.

U.DP.210.1109.en.02

Kodak

It's time for you **AND** Kodak